

# ***Installation Instructions***

## ***DSZ 120, 160, 200***

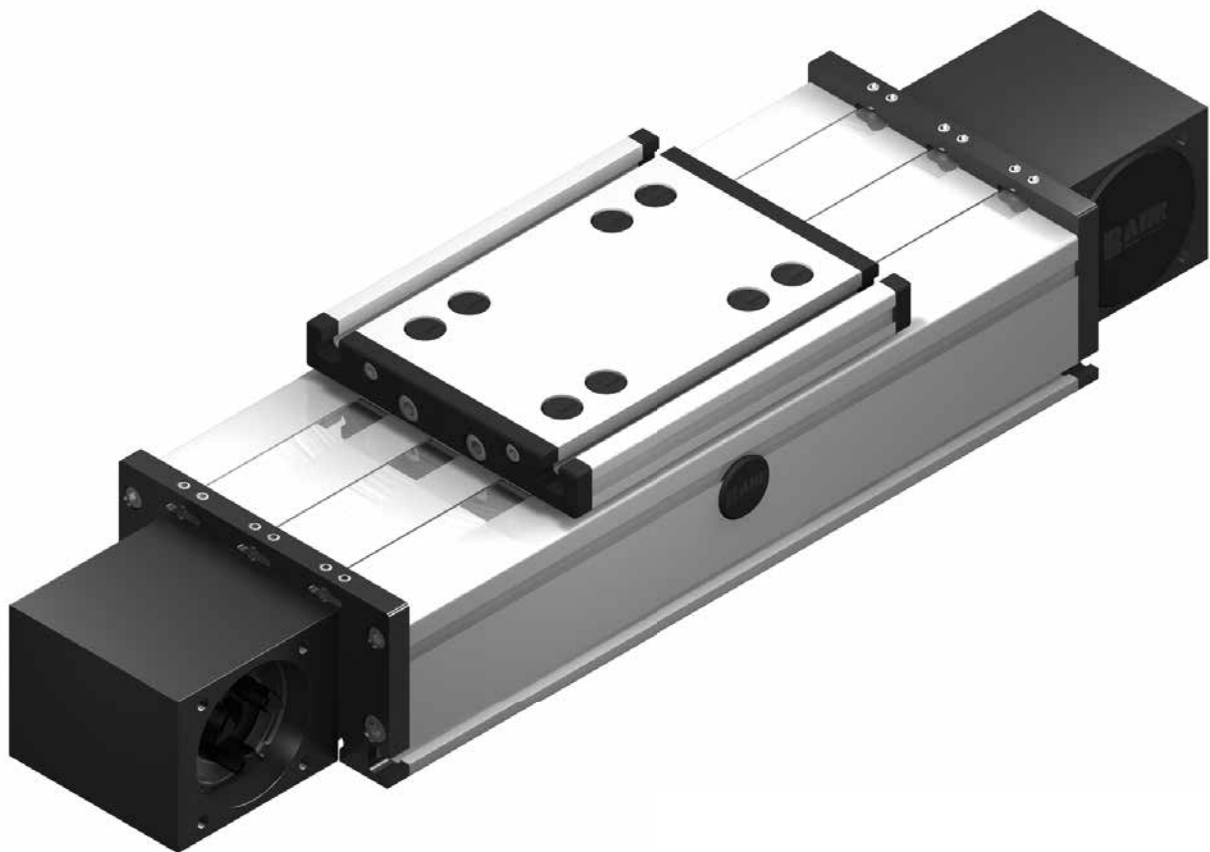

### **Bahr Modultechnik GmbH**

Nord-Süd-Straße 10a  
D-31711 Luhden

Postfach 1127  
D-31703 Bad Eilsen  
[www.bahr-modultechnik.de](http://www.bahr-modultechnik.de)

Telefon +49 (0) 5722 - 9933-0  
Telefax +49 (0) 5722 - 9933-70  
[info@bahr-modultechnik.de](mailto:info@bahr-modultechnik.de)

## 1. Safety

### 1.1 Safety Notes

Bahr Modultechnik GmbH built this state of the art positioning system in accordance with all current safety regulations. Nevertheless this positioning system may cause hazards to persons or property if it is used inappropriately or not as intended by the manufacturer or if the safety precautions are not observed.

Proper operation and careful maintenance will ensure high performance and availability of this positioning system. Any malfunctions or conditions which could affect safety must be eliminated immediately. Any person involved in the installation, use, operation or maintenance of this positioning system must have read and understood these Installation Instructions.

*This includes:*

- *understanding the safety precautions mentioned in the text; and*
- *making oneself familiar with the configuration of the various operating and usage options and how these work.*

This positioning system may be used, installed and operated by qualified personnel only. Any work on and with the positioning system must be carried out in accordance with the current instructions. For that reason, the instructions must be kept in a safe place near the positioning system so that it is always at hand. Any general, national or plant-specific safety regulations must be observed.

The responsibilities regarding the use, installation and operation of this positioning system must be unambiguously defined and complied with so that there will be no unclear competencies with regard to safety aspects. Before each start-up the user has to make sure that there are no persons or objects within the danger zone of the positioning system. The linear unit may only be used if it is in perfect working condition. Any change in condition must be reported to the next responsible person immediately.

## 1. Safety

### 1.2 Special Safety Precautions

- Any work with the positioning system must be carried out in compliance with the current instructions.
- The system may be opened by authorized skilled personnel only. In case of a defect we recommend contacting the manufacturer or returning this positioning system for repair.
- Connecting the positioning system to an electric power system may be carried out by qualified personnel only; any local connection conditions and regulations (e. g. DIN, VDE) must be observed in this respect.
- The appropriate personal protection equipment (PPE) must be worn during all work.
- Unauthorized modifications of the positioning system are prohibited due to safety reasons.
- In case of a diagonal or vertical mounting position of the positioning system, the carriage must always be secured against fall down (e. g. during mounting, dismantling, maintenance and repair work).
- The transverse forces, torques and speeds determined by Bahr Modultechnik GmbH for this positioning system must not be exceeded.
- Following an impact, the toothed belt, the ball rail guide and the runner block must be exchanged - even if there are no visible damages. For information regarding spare parts please see the spare parts list for the corresponding type of positioning system.
- The rating plate must always be maintained in a legible condition. The data must be easily retrievable at any time.
- Danger zones are marked by danger symbols for your safety (see 1.3.1).
- Safety-relevant devices must be inspected with regard to their function, integrity and completeness at regular intervals, at least once a year.

## 1. Safety

### 1.3 Safety Signs

These warning signs are safety signs warning the user against risks and dangers. Information in these Installation Instructions regarding particular hazards or dangerous situations in connection with this positioning system must be observed; non-compliance will lead to increased accident risks.



This „*General Warning Sign*“ reminds you to be careful. Sections in these Installation Instructions marked by this sign should be read and observed carefully. They contain important notes on functions, settings and procedures. Non-compliance may lead to injuries, malfunction of the positioning system or damage to surrounding equipment.



The „*Entanglement Hazard*“ sign warns of hazards due to potentially moving components. Keep hands, loose clothing and long hair away from moving parts.



The „*Hand Injury*“ sign warns against hand injuries. Hands or fingers can be crushed, pulled in or otherwise injured.



The „*Cutting Hazard*“ sign warns of sharp edges that can lead to hand injuries.

#### 1.3.1 General hazard areas on the positioning system

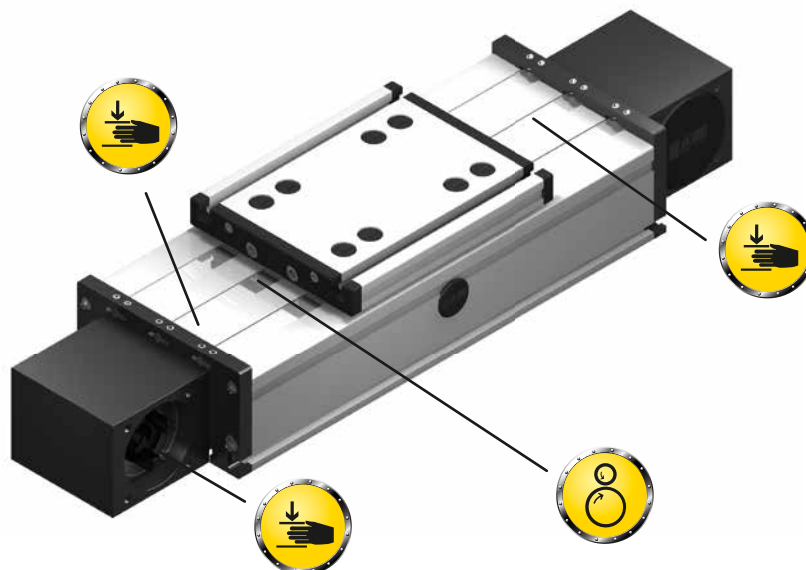

## 2. General Notes

### 2.1 Notes on these Installation Instructions

These Installation Instructions only apply to the positioning system described here and are intended to be used as documentation by the manufacturer of the final product into which this incomplete machine will be incorporated.

We explicitly point to the fact that the manufacturer of the final product has to prepare operating instructions for the end user which contain all functions and safety notes with regard to the final product.

This also applies if the positioning system is integrated into a machine. In such case, the machine manufacturer is responsible for the corresponding safety devices, inspections and for monitoring crushing or shearing points, if any, as well as for the documentation.

*These Installation Instructions will help you to*

- *avoid hazards,*
- *avoid downtimes, and*
- *to ensure or increase the life cycle of this product.*

The warnings and safety precautions as well as other requirements mentioned in these Installation Instructions must be met without exception.

Every person working with the product must read and observe these Installation Instructions.

The product may not be taken into operation unless it complies with the provisions of EC Directive 2006/42/EC (Machinery Directive). The CE Marking directives must be complied with before marketing the product; this also applies to the documentation.

We explicitly point to the fact that the secondary manufacturer who will integrate this incomplete machine/partial machine/machine part into a final product is obliged to extend and complete this documentation correspondingly. In particular, if electrical components and/or drives are integrated into the product, the secondary manufacturer has to set up a declaration of conformity. Our Declaration of Incorporation will then automatically become invalid.

### 3. Declaration of Incorporation

#### 3.1 Declaration of Incorporation

as defined by EC Machinery Directive 2006/42/EC, Appendix II, 1. B for incomplete machines.

The manufacturer

**Bahr Modultechnik GmbH**  
Nord-Süd-Str. 10a  
31711 Luhden - Germany

hereby confirms that the product:

Name: see marking on the system  
SN/ID-No: see marking on the system

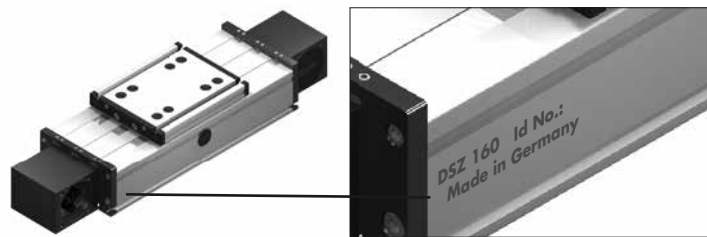

complies with the requirements regarding an incomplete machine according to EC Machinery Directive 2006/42/EC. The following basic requirements of the Machinery Directive 2006/42/EC, Appendix I, have been applied and are complied with.

The following harmonizing standards have been applied (as applicable on the date of signature):

DIN EN ISO 12100 – 1 Safety of Machinery – Basic concepts, general principles for design  
Part 1: Basic terminology, methodology

DIN EN ISO 12100 – 2 Safety of Machinery – Basic concepts, general principles for design  
Part 2: Technical principles and specifications

Bahr Modultechnik GmbH undertakes to submit the technical documentation relating to the incomplete machine according to Appendix VII B of the Directive 2006/42/EC to the relevant national authorities upon justified request (in hard copy form).

Luhden / 25.06.2012

*Location, date*

Technical documentation

*Jennifer Martitz*

This incomplete machine must not be put into operation until the machinery into which it is incorporated has been declared to be in conformity with the EC Machinery Directive 2006/42/EC.

Luhden, 25.06.2012

*Location, date*

Construction manager - Dirk Bahr

*Dirk Bahr*

## 4. Product Information

### 4.1 Working Principle

This unit consists of a rectangular aluminium profile with 2 integrated rail guides. The carriage is moved by a belt drive. Each standard pulley has got one coupling claw on one side. Belt tension can be readjusted by a simple screw adjustment device in the carriage. This device can also be used for symmetrical adjustment of two or more linear units running parallel. The openings of the guide body are sealed with 3 stainless steel cover bands to protect the guide from splash water and dust. Alternatively, the opening can also be covered with a bellow or can be delivered without cover bands.

### 4.2 Designs/Basic Lengths

This positioning system is available in the designs and guidance versions indicated in this documentation.

- Upon receipt of the positioning system, please check the system for any potential damages or missing components.
- Notify Bahr Modultechnik GmbH of any defects immediately.

The linear units are manufactured with individual lengths according to your specifications. The width and height of the linear unit result from the selected size and design and can be looked up in the Bahr Modultechnik Catalogue.

*Get personally or by downloading [www.bahr-modultechnik.de](http://www.bahr-modultechnik.de)*

## 4. Product Information

### 4.3 Forces and Torques

| Size   | 120                   |          | 160                   |          | 200                   |          |
|--|-----------------------|----------|-----------------------|----------|-----------------------|----------|
|  | 5000 km               | 10000 km | 5000 km               | 10000 km | 5000 km               | 10000 km |
| <b>permitted dyn. Forces*</b>  |                       |          |                       |          |                       |          |
| $F_x$ (N)  | 894                   | 800      | 1900                  | 1800     | 4000                  | 3800     |
| $F_y$ (N)  | 1776                  | 1405     | 2236                  | 1775     | 5155                  | 4092     |
| $F_z$ (N)  | 2090                  | 1650     | 5278                  | 4189     | 11311                 | 8977     |
| $M_x$ (Nm)   | 81                    | 64       | 282                   | 224      | 752                   | 597      |
| $M_y$ (Nm)   | 97                    | 77       | 283                   | 225      | 813                   | 646      |
| $M_z$ (Nm)   | 96                    | 76       | 300                   | 238      | 862                   | 684      |
| <b>All forces and torques related to the following:</b>  |                       |          |                       |          |                       |          |
| existing values $\frac{F_y}{F_{y_{dyn}}} + \frac{F_z}{F_{z_{dyn}}} + \frac{M_x}{M_{x_{dyn}}} + \frac{M_y}{M_{y_{dyn}}} + \frac{M_z}{M_{z_{dyn}}} \leq 1$ |                       |          |                       |          |                       |          |
| table values $F_{y_{dyn}}, F_{z_{dyn}}, M_{x_{dyn}}, M_{y_{dyn}}, M_{z_{dyn}}$   |                       |          |                       |          |                       |          |
| <b>No-load torque</b>  |                       |          |                       |          |                       |          |
| Nm without cover bands   | 1,2                   |          | 1,5                   |          | 2,0                   |          |
| Nm with cover bands  | 1,6                   |          | 2,1                   |          | 2,9                   |          |
| <b>Speed</b>   |                       |          |                       |          |                       |          |
| (m/s) max  | 5                     |          | 5                     |          | 5                     |          |
| <b>Tensile force</b>   |                       |          |                       |          |                       |          |
| permanent (N)  | 900                   |          | 1900                  |          | 4000                  |          |
| 0,2 s (N)  | 1000                  |          | 2090                  |          | 4300                  |          |
| <b>Geometrical moments of inertia of aluminium profile</b>   |                       |          |                       |          |                       |          |
| $I_x$ mm <sup>4</sup>  | 5,61x10 <sup>5</sup>  |          | 2,13x10 <sup>6</sup>  |          | 4,81 x10 <sup>6</sup> |          |
| $I_y$ mm <sup>4</sup>  | 34,19x10 <sup>5</sup> |          | 12,33x10 <sup>6</sup> |          | 26,0 x10 <sup>6</sup> |          |
| Elastic modulus N/mm <sup>2</sup>  | 70000                 |          | 70000                 |          | 70000                 |          |

\* referred to life-time



## 5. Use/Operating Personnel

### 5.1 Intended Use

The positioning system may be used only for linear moving and positioning of workpieces, assemblies, measuring devices or similar tasks of comparable nature in industrial plants.

The linear unit must not be used in explosive atmospheres or in direct contact with foodstuffs, pharmaceutical or cosmetic products.

Catalogue information, the contents of these Installation Instructions and conditions stipulated in the order documents must be observed. The load data indicated in these Installation Instructions are maximum values which must not be exceeded. Overloads in any other areas must be avoided as well.

### 5.2 Improper Use

„Improper use“ is any use not in compliance with the requirements mentioned in chapter 5.1 Intended Use.

In the event of improper use, inappropriate treatment or if this positioning system is used, installed or handled by unskilled personnel, this linear unit may cause hazards for the staff.

If this positioning system is used improperly, Bahr Modultechnik GmbH accepts no liability and the general operating permit will become null and void.

#### 5.2.1 Cases of Frequent Misuse

- Use in explosive atmospheres (if used in explosive areas, sparks can lead to deflagrations, fire or explosions)
- Use of the linear unit with tolerance exceeded
- Insufficient securing of the positioning system
- Insufficient securing of the loads to be moved
- Loads exceeding the indicated limits
- Use in the food industry with direct contact with unpacked foodstuffs
- Use outdoors
- Use in an environment with high humidity > dew point
- Use in heavily contaminated environments
- Use in extremely dusty atmospheres
- Use in atmospheres containing solvents
- Moving animals
- Use in liquids
- Use in temperatures below -10°C and above 60°C

### 5.3 Who may Use, Install and Operate this Linear Unit

Any authorized persons who have read and understood these Installation Instructions completely are allowed to use, install and operate this positioning system. The responsibilities for handling this positioning system must be clearly defined and adhered to.

## 6. Life Stages

### 6.1 Transport and Storage

When transporting the linear units, you must ensure that a crane, lifting truck or even persons do not grip the unit at the end elements. The load must be sufficiently secured during transport and the centre of gravity must be observed in order to prevent the load from tilting.

- Never stand or walk under the load. Respective P.P.E. ( Personal Protective Equipment) must be worn during all measures.
- Accident prevention regulations and safety precautions must be observed.
- During transport and storage, impacts or hits on the shaft ends or driving journals must be avoided.

Any damages due to transport or storage must be reported to the responsible person and Bahr Modultechnik GmbH immediately. The product must be checked for any visible and functional defects by qualified personnel. The start-up of damaged linear units is prohibited.

The following environmental conditions are prescribed for storing the linear unit:

- no oil contaminated air
- contact with solvent-based lacquers must be prevented
- lowest/highest ambient temperature: 0°C/+60°C
- humidity during storage: storage below dew point is inadmissible
- Supporting the complete surface of the profile body or an appropriate number of support points along the length of the guide profile will prevent the linear unit from deforming.

Any environmental conditions deviating from the requirements described above will have to be approved by Bahr Modultechnik GmbH.

## 6. Life Stages

### 6.2. General

- Before installation, the corrosion protection at the shaft ends of the driven linear units must be removed.
- Cleaning agents must be prevented from entering the bearings.
- When installing transmission elements such as couplings or motor adapters, impacts or hits on the shaft ends and driving journals must be avoided in order to prevent the bearing from being damaged or becoming unbalanced.
- The linear unit must be secured on a level surface with a planarity of 0.20 mm/m.
- The linear unit must not be warped during installation.
- When the system is to be operated, sufficient fixing points must be selected between and linear unit and the mounting surface.
- The loads to be moved by the linear unit must be secured properly and sufficiently for the corresponding application.
- The high dead weight of the component parts and the linear unit presents hazard for people and property.
- When mounting a motor on the linear unit, ensure that the motor shaft and the drive shaft of the linear unit are axially aligned.

## 6. Life Stages

### 6.2.1 Locking Torques

Locking torque guidance values for metric cylinder head screws ISO 4762 with 90% utilisation of the 0.2% yield strength, for a friction coefficient of 0,14.

| Dimensions | Strength 8.8<br>Locking torques $M_A$ (Nm) | Strength 10.9<br>Locking torques $M_A$ (Nm) | Strength 12.9<br>Locking torques $M_A$ (Nm) |
|------------|--|---|---|
| M4         | 3,0  | 4,4   | 5,1   |
| M5         | 5,9  | 8,7   | 10  |
| M6         | 10   | 15  | 18  |
| M8         | 25   | 36  | 43  |
| M10        | 49   | 72  | 84  |

Please read the installation instructions for the accessories to obtain information regarding your specific application.

### 6.2.2 Installation with Fasteners

The specific locking torques of the screws used for installation must always be observed. Please pay attention to the steel grade of the screws and any special information provided with the accessories. The safety and useful life of the linear axis are only guaranteed if all these conditions are met. The values can be taken from the table in these Installation Instructions.

### 2-piece mounting block sets / assembly plate

Assembly plate, anodized aluminium, enables various units to be assembled in a simple manner when combinations of linear units are to be used. Complete with screws and slide-nuts. Tapped holes can be made on request.

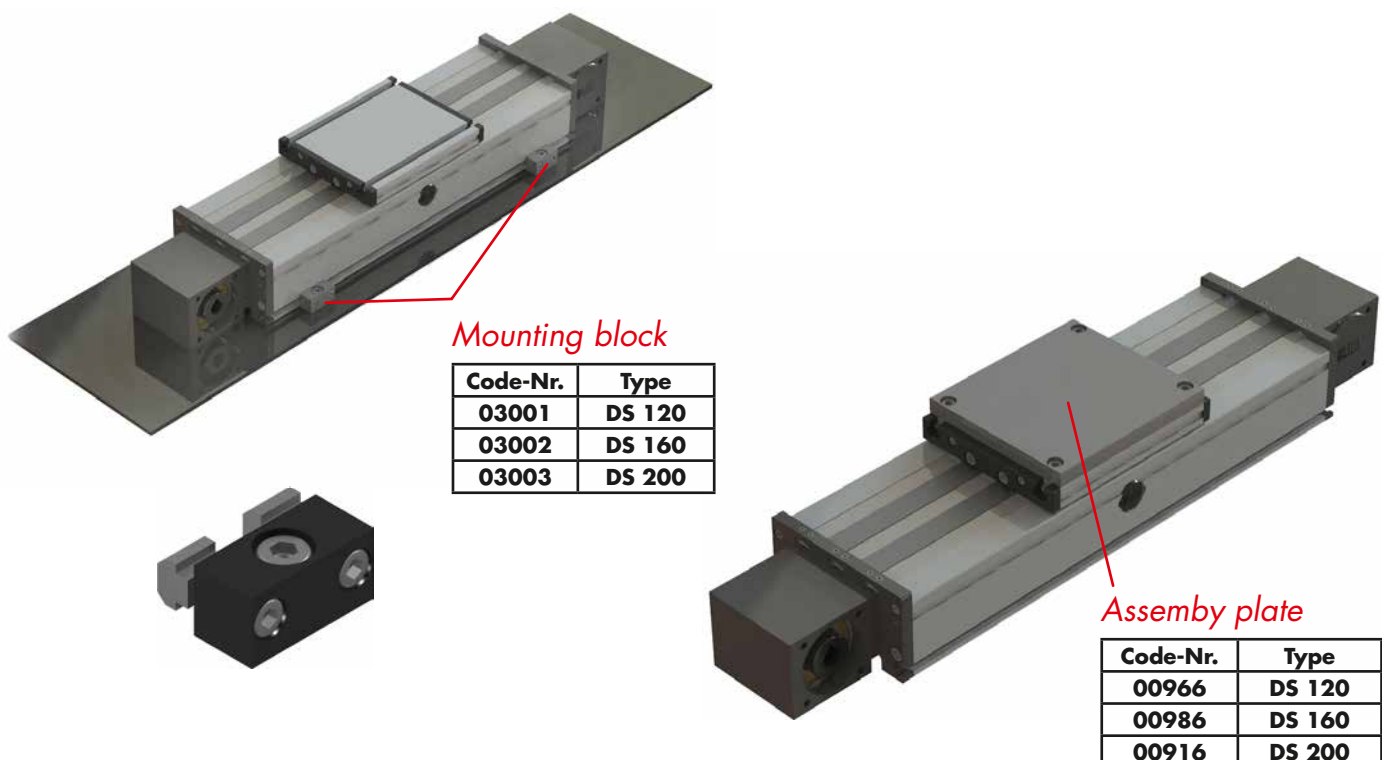

## 6. Life Stages

### 6.2.3 Installation of optional accessories

#### Mechanical or inductive limit switches

For details regarding the technical characteristics of the limit switches please see the catalogue. Ensure that the cable is laid in a safe way. Avoid damages to the cable e. g. due to small radiuses; this may lead to failure of the system. The cable must not enter the travelling path of the linear unit.

#### Mechanical limit switch

The switch is installed by means of a limit or proximity switch bracket which is mounted onto the guide profile. The limit and proximity switch brackets can be moved along the guide profile and fixed in the desired position.



#### Inductive limit switches

The assembly of the proximity switch is a limit and proximity switch bracket that is mounted on the guide profile. The final and proximity switch brackets are moved and fixed to the guide profile.



## 6. Life Stages

### 6.2.4 Coupling/Motor Adapter/Motor

The motor can be installed on the pulley with or without gears.  
To ensure that this positioning system does not cause a risk, the drive must be designed correctly.

The design and manufacture of the motor adapter must ensure that no axial, radial or angular misalignment can occur.  
The installation of the motor follows a logical sequence.  
One coupling half is mounted on the pivot of the positioning system.  
The second coupling half is mounted on the drive and pushed through the installed motor adapter on the positioning system which has been prior equipped with the other coupling half.

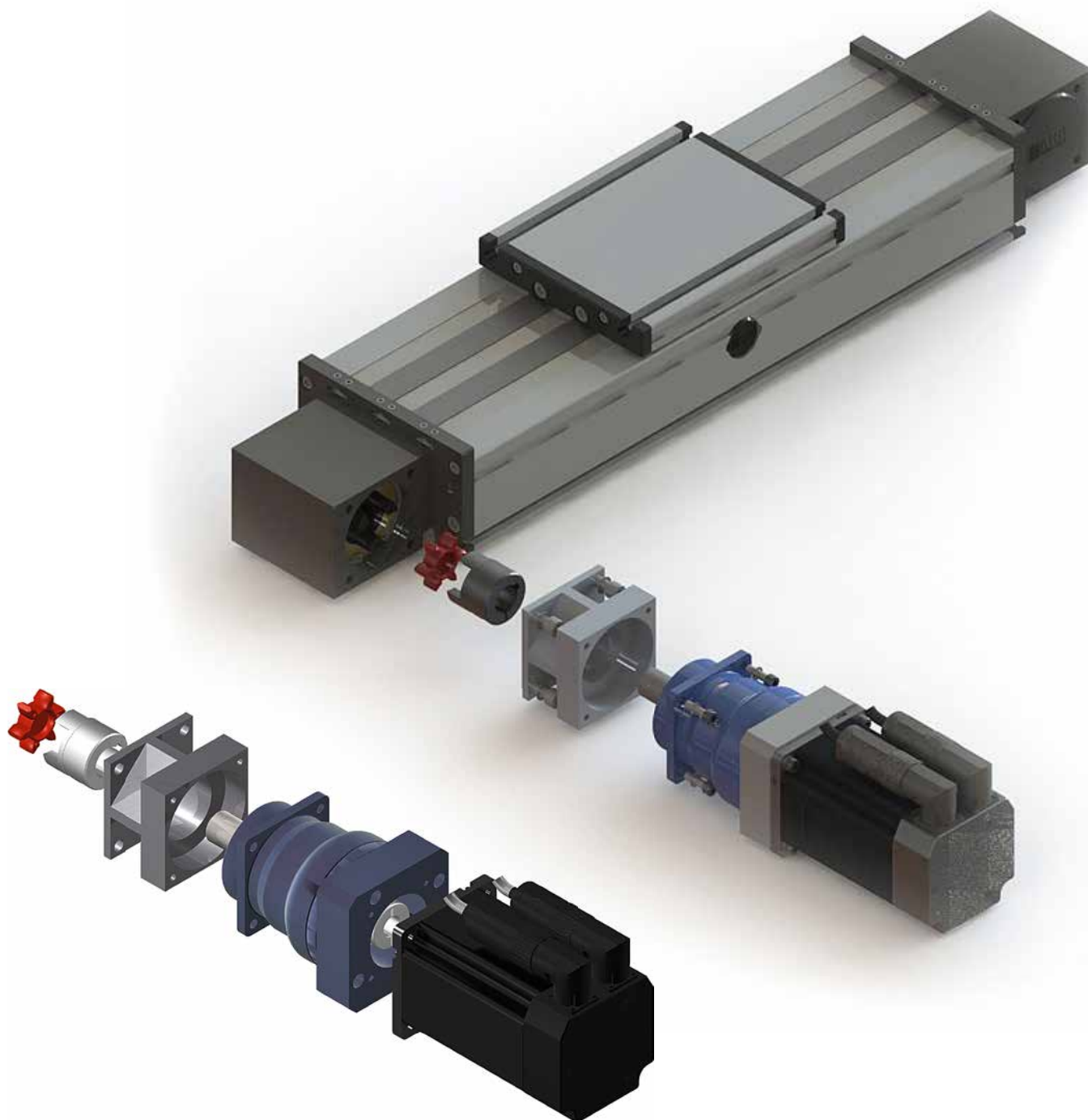

## 6. Life Stages

### 6.2.5 Installation of Coupling and Motor

There are two methods to install the motor, either without gears or with a planetary gear.

The manufacturing tolerance are very low, therefore we recommend buying the adapter directly from Bahr Modultechnik. Angular misalignments and misalignments with respect to the centre of the adapter can lead to serious damages at the coupling and the bearings.

Another source of defect is the possibility that the coupling knobs might hit each other. Before installing the motor, the safety distances of 1 mm must be checked.

Installation of coupling and motor - pivot variant with/without feather key

- Clean the pivot and coupling clamping area using solvent
- If necessary, slightly push the coupling hub apart with the help of a screw driver



- Push the coupling onto the pivot with the whole hub length and tighten with the permitted torques



- Check the safety distances of the coupling knobs (min. 1 mm).

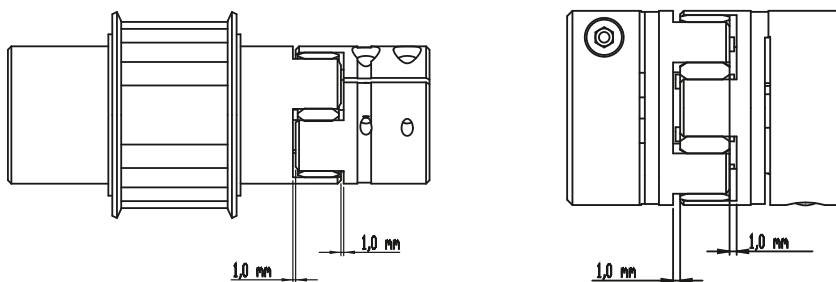

- Push the motor into the adapter and fix it

## 6. Life Stages

### 6.3 Commissioning

Only authorized persons who have read and understood these Installation Instructions completely are allowed to take this positioning system into operation. When this linear unit is in operation, forces arise which can lead to injuries and property damages. It is imperative that the safety rules and limits of the linear unit are observed.

#### 6.3.1 Normal Operation

While the linear unit is in operation, check it for correct performance of its function regularly. During normal operation, look for any visible changes of the incomplete machine. If defects should arise, shut down the linear unit immediately in order to avoid damage. According to Machinery Directive 2006/42/EC, the operating instructions of the complete machine are relevant because this incomplete machine is an element of a complete unit.

### 6.4 Maintenance/Repair/Cleaning



Before starting any work on the linear unit, any electrical drives must be isolated!

All linear units are provided with the required lubricant quantity in the factory.  
Lubricant recommendation: see section 8.2 Lubricants

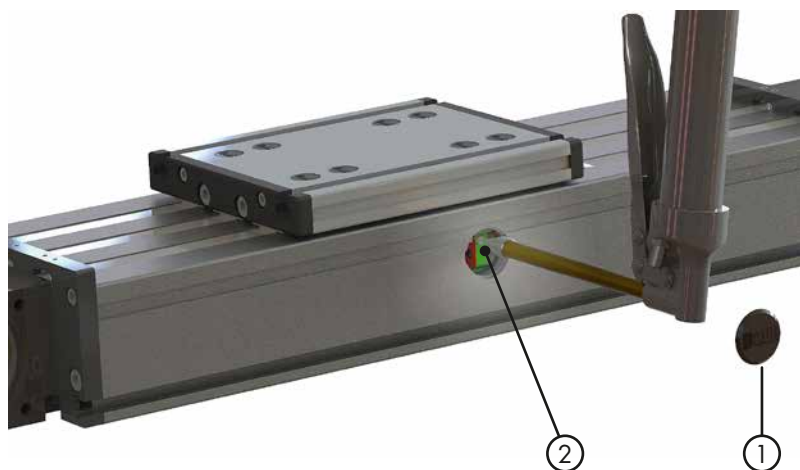

- Dismount cover cap (1).
- Drive the carriage through the service position until you can see the first greasing nipple (2) in the lubrication hole.
- Re-greasing with grease gun.
- Move the carriage to the next greasing nipple and re-grease here as well.

*We recommended bearing grease based on DIN 51825.  
The required regreasing intervals depend on environmental conditions,  
the standard recommendation is once per 1.000 km.*



## 6.4 Maintenance/Repair/Cleaning

### Belt tension adjustment DSZ 120, 160, 200

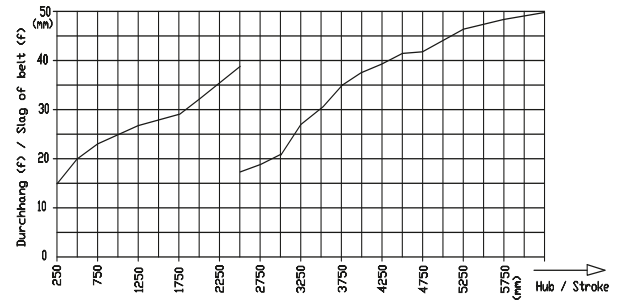
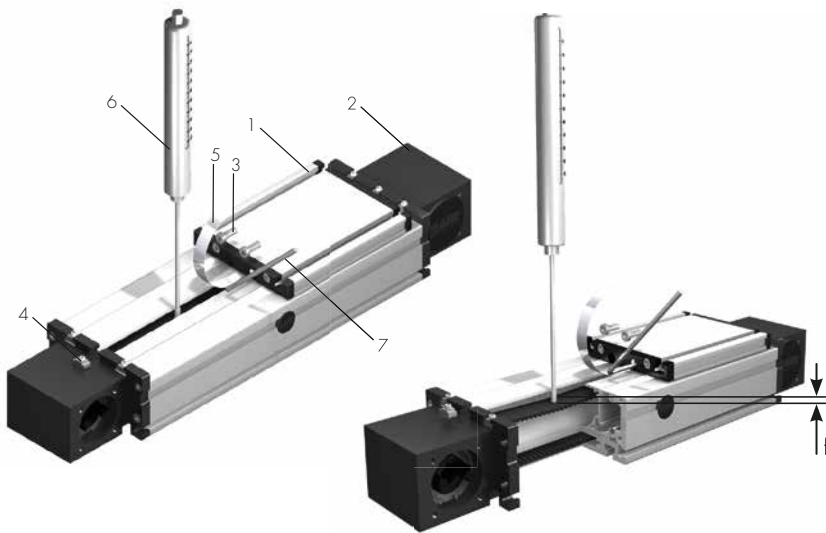

| Baugröße / Size | Hub / Stroke (mm) | Kraft / Force (N) |
|-----------------|-------------------|-------------------|
| <b>120</b>      | < 2500            | 20                |
|                 | 2500 - 6000       | 10                |
| <b>160</b>      | < 2500            | 20                |
|                 | 2500 - 6000       | 10                |
| <b>200</b>      | < 2500            | 40                |
|                 | 2500 - 6000       | 20                |

- Push the carriage (1) close to one bearing block (2).
- Remove fillister head screws (3).
- Unscrew set screws (4) for middle cover band (5) at the opposite bearing block.
- Pull cover band out of bearing block and turn it to the side.
- Use spring balance (6) to exert the applicable amount of force (see table) on the center of the belt and measure the sag (f).
- Compare the measured value with the diagram below, and tense or release belt as required by tightening or unscrewing the set screws (7).
- The set screws (7) must be bonded in place with screw locking device.
- Both screws (7) must be screwed in to exactly the same level. Check with sliding caliper.

### Changing cover band DSZ 120, 160, 200

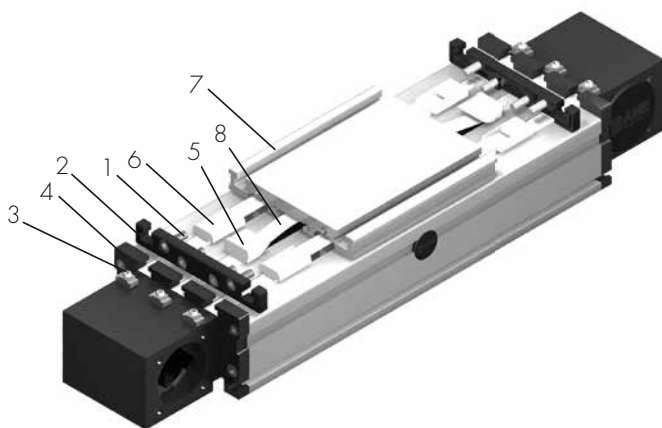

- Drive the carriage to servicing position
- Remove fillister head screws (1) and wiper end plate (2)
- Size 160 and 200: Unscrew set screws (3) at both bearing-block plates (4) and pull the cover band out of the bearing block
- Size 120: Unscrew set screws and remove them with T-nut
- Remove sliders (5) and (6) from both sides of the carriage (7)
- Pull the cover bands (8) out of the carriage
- Insert the new cover bands into the carriage (7)
- Thread the lateral sliders (6) onto the cover band and insert it into the carriage with middle slider (5)
- Size 160 and 200: Tighten cover bands on one side of the bearing block with set screws (3), tense cover band (8) at the other bearing block using pliers and tighten with set screws (3)
- Size 120: Insert T-nut together with set screw into the bearing block and tighten cover band with set screw.

## 6.4 Maintenance/Repair/Cleaning

### Belt exchange DSZ

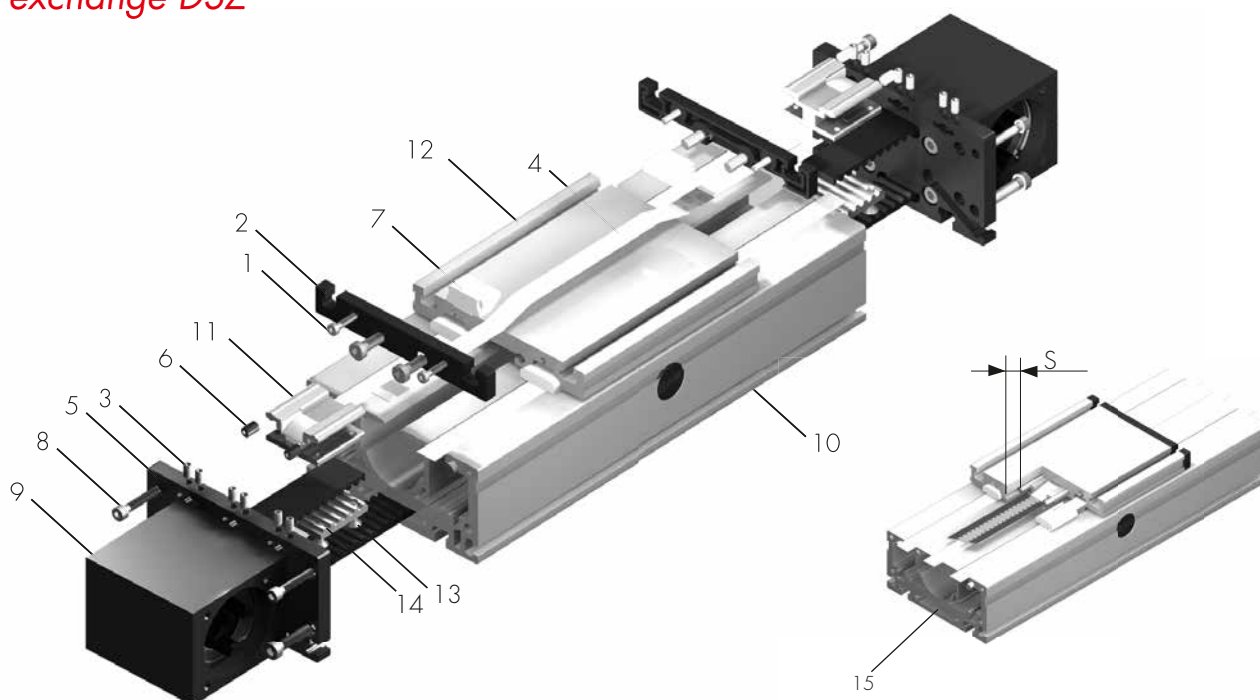

### Changing belt of DS 120, 160, 200

- Unscrew cylindric screws (1) and dismount cover caps (2) on both sides of the carriage.
- Unscrew grub screws (3) on both sides of the unit and pull out the only the middle cover band (4) of the bearing-block plate (5).
- Measure the reach of grub screws „S“ (look at drawing) and make note of this value.
- Unscrew grub crews (6) on both sides of the carriage.
- Pull only the middle sliding blocks (7) out of the carriage.
- Unscrew cylindric screws (8) at the bearing-block plates (5) and dismount them completely with the bearing-blocks (9) at both ends of the unit.
- Pull out the belt-adjusters (11) completely with the belt out of the carriage (12) and the guiding-profile (10).
- Unscrew the countersunk head screws (13) and dismount the belt-adjuster (11, 14).

### Reconstruction of the unit in opposed order

- Shorten the new belt to the length of the old one.
- Push the belt with teeth side up to the carriage (10) into the slot of the guiding-profile (15) and push it with the ends through each bearing-block (8,9).
- Mount the belt-adjusters (11, 14) by the countersunk head screws (13) and lock them again with glue.
- Push them again together with the belt into the guiding-profile (10) and then into the carriage (12).
- Mount the bearing-block plates (8) again together with the bearing-blocks (9) at the ends of the unit.
- Mount both belt-adjusters (11, 14) with consideration of the reach of the grub-screws „S“ and lock the grub screws (6) with glue.
- Pull the middle cover-band (4) through the carriage.
- Pull in the middle sliding blocks (7) into slot of the carriage.
- Mount the grub screws (3) on one side of the unit and tension the 3 cover-bands from the other side and fix them too by the grub-screws (3).

## 6. Life Stages

### 6.5 Decommissioning/Dismantling



Before starting any work on the linear unit, any electrical drives must be isolated.

On linear units in diagonal or vertical mounting positions, the connecting rod must be secured against falling down when the drive is dismantled. Any loads and forces acting on the system must be removed. Following an impact, the system must be returned to the manufacturer, even if there are no visible damages.

For information regarding spare parts please see the spare parts list for the corresponding type of linear unit.

### 6.6 Disposal and Returns

The linear unit must either be disposed of in an environmentally friendly way according to the applicable directives and regulations, or returned to the manufacturer.

The manufacturer reserves the right to charge a fee for the disposal of this linear unit.

## 7. Liability/Warranty

### 7.1 Liability

Bahr Modultechnik GmbH does not accept any liability for damages or impairments which occur as a result of modifications of the construction of this positioning system by third parties or modifications of protection devices.

Only original spare parts may be used for repairs and maintenance.

Bahr Modultechnik GmbH does not accept liability for spare parts which it has not inspected and approved.

Otherwise the EC Declaration of Incorporation will become null and void.

Safety-relevant devices must be inspected with regard to their function, integrity and completeness at regular intervals, at least once a year.

We reserve the right to make technical changes to the positioning system and to modify or amend these Installation Instructions.

Requests to Bahr Modultechnik GmbH regarding the availability of earlier versions or adaptations to the current version of the positioning system will not be accepted.

If you have any questions, please always quote the information on the rating plate.

Our address:

Bahr Modultechnik GmbH  
Nord-Süd-Str. 10a  
31711 Luhden - Germany

Tel.: +49 (0) 5722 9933-0  
Fax: +49 (0) 5722 9933-70

<http://www.bahr-modultechnik.com>

### 7.2 Product Monitoring

Bahr Modultechnik GmbH offers state-of-the-art products compliant with current safety standards. Please let us know immediately if you experience repeated failures or faults.

### 7.3 Language of the Installation Instructions

The original version of these Installation Instructions was produced in the official EU-language used by the manufacturer of this incomplete machine. Translations into other languages are translations of the original version and are subject to the legal provisions of the Machinery Directive.

### 7.4 Copyright

Individual reproductions, e. g. copies and printouts, may be made for private use only. The production and distribution of further reproductions is prohibited unless explicitly approved by Bahr Modultechnik GmbH. The user is personally responsible for complying with statutory regulations and may be liable for misuse.

The copyright to these Installation Instructions is owned by Bahr Modultechnik GmbH.

## 8. Parts Lists / Exploded Drawings

### 8.1 Parts Lists / Exploded Drawings

Please see the parts lists for the standard naming of the parts as defined by Bahr Modultechnik GmbH as well as the corresponding installation positions on the linear axis. Please always indicate the name, the item No. and the quantity in your orders. Technical variations are possible and depend on the size and version of the positioning system.

| Pos. | Name               | Code-No.  | Quantity |
|------|--------------------|---|----------|
| 1    | guide body profile | The code number and quantity depends on the unit version. |          |
| 2    | cover cap          |   |          |
| 3    | guide rail         |   |          |
| 4    | pulley-block       |   |          |
| 5    | belt               |   |          |
| 6    | runner block       |   |          |

| Pos. | Name          | Code-No.   | Quantity |
|------|---------------|--|----------|
| 7    | carriage      | Please contact our technical support with the number of the origin order.<br>In order to avoid mistakes when purchasing spare parts. |          |
| 8    | belt adjuster |  |          |
| 9    | cover band    |  |          |
| 10   | guide rail    |  |          |
|      |               |  |          |
|      |               |  |          |

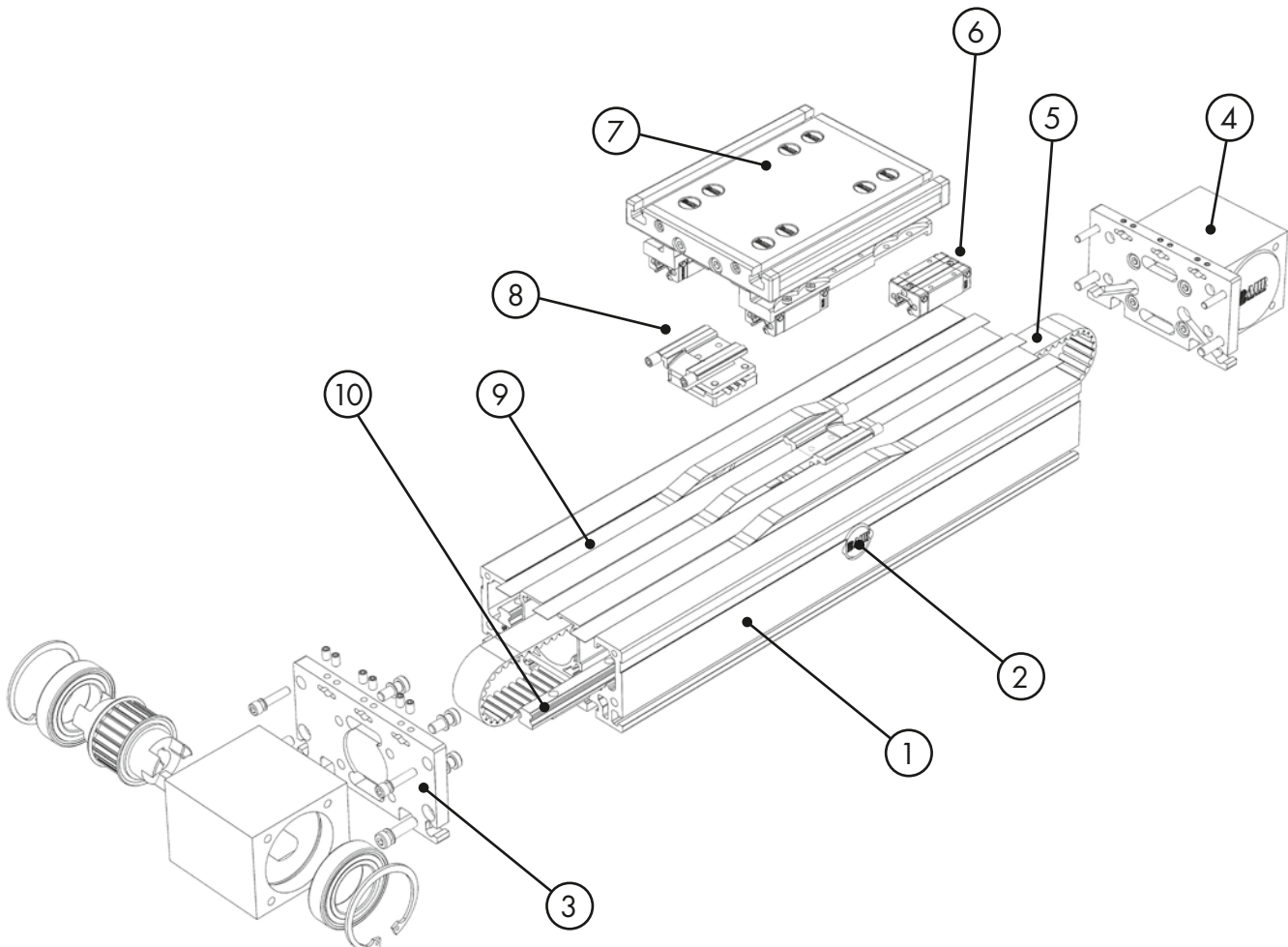

## 8. Parts Lists / Exploded Drawings

### 8.2 Lubricants

All Bahr Modultechnik GmbH products are delivered EX Works with standard lubrication. Subsequent lubrication intervals are dependent on hours run, degree of loading and environmental factors (wide temperature ranges, high humidity, aggressive environment etc.).

The lubricants listed below are used for production and mounting of our linear components. To achieve perfect operation and a useful, prolonged life, we recommend the following products:

#### **For guide rail and runner block.**

|                    |                   |
|--------------------|-------------------|
| Grease:            | SKF LGMT 2/1      |
| DIN 51502:         | K2K -30           |
| Temperature range: | -30°C till +120°C |
| Code-Number:       | 09002             |

